

TOOLING

10-2022

APRIL 2022

METRIC

NPA

New Product Announcement

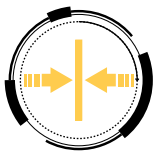

Slim Design Thermal Shrink Chucks



Coolant Directed to Cutting Edges

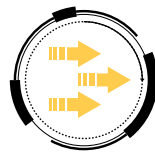

High Speed Milling



X-STREAM
JET TOOLHOLDING

SHRINKiN

NEW Slim Design Thermal Shrink Chucks (SRK-CX) with Coolant Jet Channels Along the Shank Bore

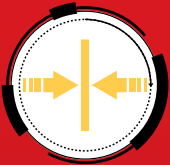

Slim Design
Thermal Shrink
Chucks



Coolant Directed
to Cutting Edges

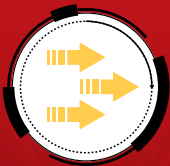

High Speed Milling

NPA

New Product Announcement

X-STREAM **SHRINKiN**
JET TOOLHOLDING

Highlights

NEW SRK-CX Slim Design Shrink Chucks with Coolant Jet Channel Technology

The new SRK-CX is a unique and extraordinary product line, which follows ISCAR's X-STREAM patented coolant jet channels technology. **These are the slimmest shrink chucks in the market with direct coolant to the cutting edge.**

Features

- Coolant directed to cutting edges
- Prolonged tool life
- Eliminates chip sticking to the cutting edges
- Suitable for **High Speed Milling**
- Effective chip evacuation prevents chip recutting

Applications and Advantages

- CNC milling machines with poor external coolant flow
- Milling cavities and pockets
- Semi-finish and finishing profile milling of titanium blisk blades
- Milling applications with intensive heat generation, such as very hard alloy steels, high-temperature alloys. etc.

Note: Preset CX screw allows coolant supply via jet channels - not to be removed!

Availability

In stock.

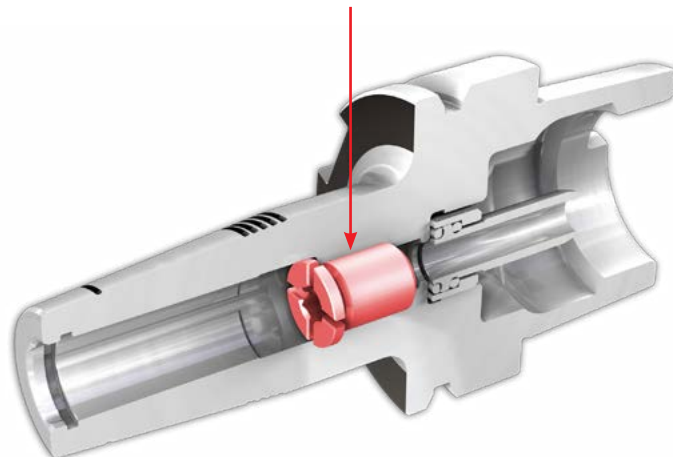

X-STREAM
JET TOOLHOLDING

SHRINKIN

HSK A-SRK-CX

Thermal Shrink Chucks with HSK DIN69893 Form A Tapered Shank and Coolant Jet Channels for Solid Carbide Tools Only

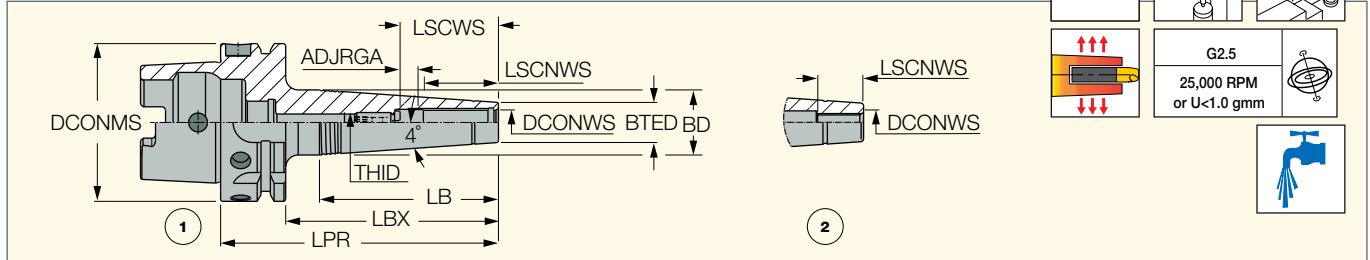

Designation	DCONMS	DCONWS	BTED	BD	LPR	LBX	LB	ADJRGA	LSCWS	LSCNWS	THID	Key	CDI ⁽²⁾	Fig.	kg
HSK A63 SRK 3X50 CX ⁽¹⁾	63.00	3.00	10.00	17.00	76.00	50.00	-	-	-	10.00	-	-	1	2	0.77
HSK A63 SRK 3X85 CX ⁽¹⁾	63.00	3.00	10.00	21.00	111.00	85.00	78.70	-	-	10.00	-	-	1	2	0.84
HSK A63 SRK 4X50 CX ⁽¹⁾	63.00	4.00	10.00	17.00	76.00	50.00	-	-	-	12.00	-	-	1	2	0.77
HSK A63 SRK 4X85 CX ⁽¹⁾	63.00	4.00	10.00	21.00	111.00	85.00	78.70	-	-	12.00	-	-	1	2	0.83
HSK A63 SRK 5X50 CX ⁽¹⁾	63.00	5.00	10.00	17.00	76.00	50.00	-	-	-	15.00	-	-	1	2	0.77
HSK A63 SRK 5X85 CX ⁽¹⁾	63.00	5.00	10.00	21.00	111.00	85.00	78.70	-	-	15.00	-	-	1	2	0.83
HSK A63 SRK 6X50 CX	63.00	6.00	11.00	18.00	76.00	50.00	-	8.90	26.90	18.00	M5	2.50	1	1	0.78
HSK A63 SRK 6X85 CX	63.00	6.00	11.00	22.00	111.00	85.00	78.70	8.90	26.90	18.00	M5	2.50	1	1	0.86
HSK A63 SRK 8X50 CX	63.00	8.00	14.00	20.00	76.00	50.00	42.90	9.50	34.50	25.00	M6	3.00	1	1	0.69
HSK A63 SRK 8X85 CX	63.00	8.00	14.00	23.00	111.00	85.00	64.40	9.50	34.50	25.00	M6	3.00	1	1	0.90
HSK A63 SRK 10X50 CX	63.00	10.00	16.00	23.00	76.00	50.00	-	9.50	39.50	30.00	M6	3.00	1	1	0.81
HSK A63 SRK 10X85 CX	63.00	10.00	16.00	26.00	111.00	85.00	71.50	9.30	39.30	30.00	M8	4.00	1	1	0.56
HSK A63 SRK 12X50 CX	63.00	12.00	20.00	27.00	76.00	50.00	-	9.50	41.50	32.00	M6	3.00	1	1	0.85
HSK A63 SRK 12X85 CX	63.00	12.00	20.00	30.00	111.00	85.00	71.50	9.30	41.30	32.00	M10	5.00	1	1	1.01

• A cooling tube must be used with all coolant through HSK spindles (should be ordered separately). • For solid carbide tools • Preset screw CX allows supply of coolant via JET channels - not to be removed!

⁽¹⁾ Without preset screw

⁽²⁾ 1 - Hole for data chip, 0 - Without hole for data chip

Spare Parts

Designation	Preset Screw	Cooling Tube	Wrench
HSK A63 SRK 3X50 CX		COOLING TUBE HSK A63*	WRENCH COOL TUBE HSK63*
HSK A63 SRK 3X85 CX		COOLING TUBE HSK A63*	WRENCH COOL TUBE HSK63*
HSK A63 SRK 4X50 CX		COOLING TUBE HSK A63*	WRENCH COOL TUBE HSK63*
HSK A63 SRK 4X85 CX		COOLING TUBE HSK A63*	WRENCH COOL TUBE HSK63*
HSK A63 SRK 5X50 CX		COOLING TUBE HSK A63*	WRENCH COOL TUBE HSK63*
HSK A63 SRK 5X85 CX		COOLING TUBE HSK A63*	WRENCH COOL TUBE HSK63*
HSK A63 SRK 6X50 CX	PRESET CX M5X13	COOLING TUBE HSK A63*	WRENCH COOL TUBE HSK63*
HSK A63 SRK 6X85 CX	PRESET CX M5X13	COOLING TUBE HSK A63*	WRENCH COOL TUBE HSK63*
HSK A63 SRK 8X50 CX	PRESET CX M6X12	COOLING TUBE HSK A63*	WRENCH COOL TUBE HSK63*
HSK A63 SRK 8X85 CX	PRESET CX M6X12	COOLING TUBE HSK A63*	WRENCH COOL TUBE HSK63*
HSK A63 SRK 10X50 CX	PRESET CX M6X12	COOLING TUBE HSK A63*	WRENCH COOL TUBE HSK63*
HSK A63 SRK 10X85 CX	PRESET CX M8X16	COOLING TUBE HSK A63*	WRENCH COOL TUBE HSK63*
HSK A63 SRK 12X50 CX	PRESET CX M6X12	COOLING TUBE HSK A63*	WRENCH COOL TUBE HSK63*
HSK A63 SRK 12X85 CX	PRESET CX M10X16	COOLING TUBE HSK A63*	WRENCH COOL TUBE HSK63*

* Optional, should be ordered separately

